

Alto 2

3-stage dual motor standing bench desk frame

HAFD233



Desktops sold separately

Features

Fast and smooth height adjustment - no juddering

Programmable control panel with 3 height memory presets, digital height display and reminder timer

Advanced anti-collision safety system senses change in the electrical current to the motor in the event of a collision. Additional sensor in the control box detects when the desk is not level. Either condition will cause the motor to stop and return 50mm in the opposite direction. Sensitivity is adjusted through the control panel.

Ultra quiet motors, lower than 50dB

Holeless square column legs

Easy to assemble

Available in black, white or grey

Frame	3 stage holeless square columns Optional integrated cable tray
Frame Finishes	Black / White
Height range	580-1230 mm
Stroke length	650mm
Load capacity	275lbs / 125kg
Motor	Twin/Dual motors, 38mm/s Advanced anti-collision safety system with adjustable sensitivity
Power	100-240V, max. 450W, low standby power <0.5W (3.1m power cable)
Noise level	<50dB
Desktop capacity	W1100-1900 x D700-800 mm
Control panel	Height adjustment (up/down) 3 height memory presets Height display Reminder timer function
Warranty	5 years
Certification	CB, CE-EMC, CE-LVD, RoHS, FCC, UL, CUL, RCM
Boxed Dimensions (1) x 2 boxes	W1160 x D250 x H220 mm
Boxed Weight (1)	33kg each *Caution: Heavy*
Boxed Dimensions (2)	W760 x D180 x H150 mm
Boxed Weight (2)	6kg



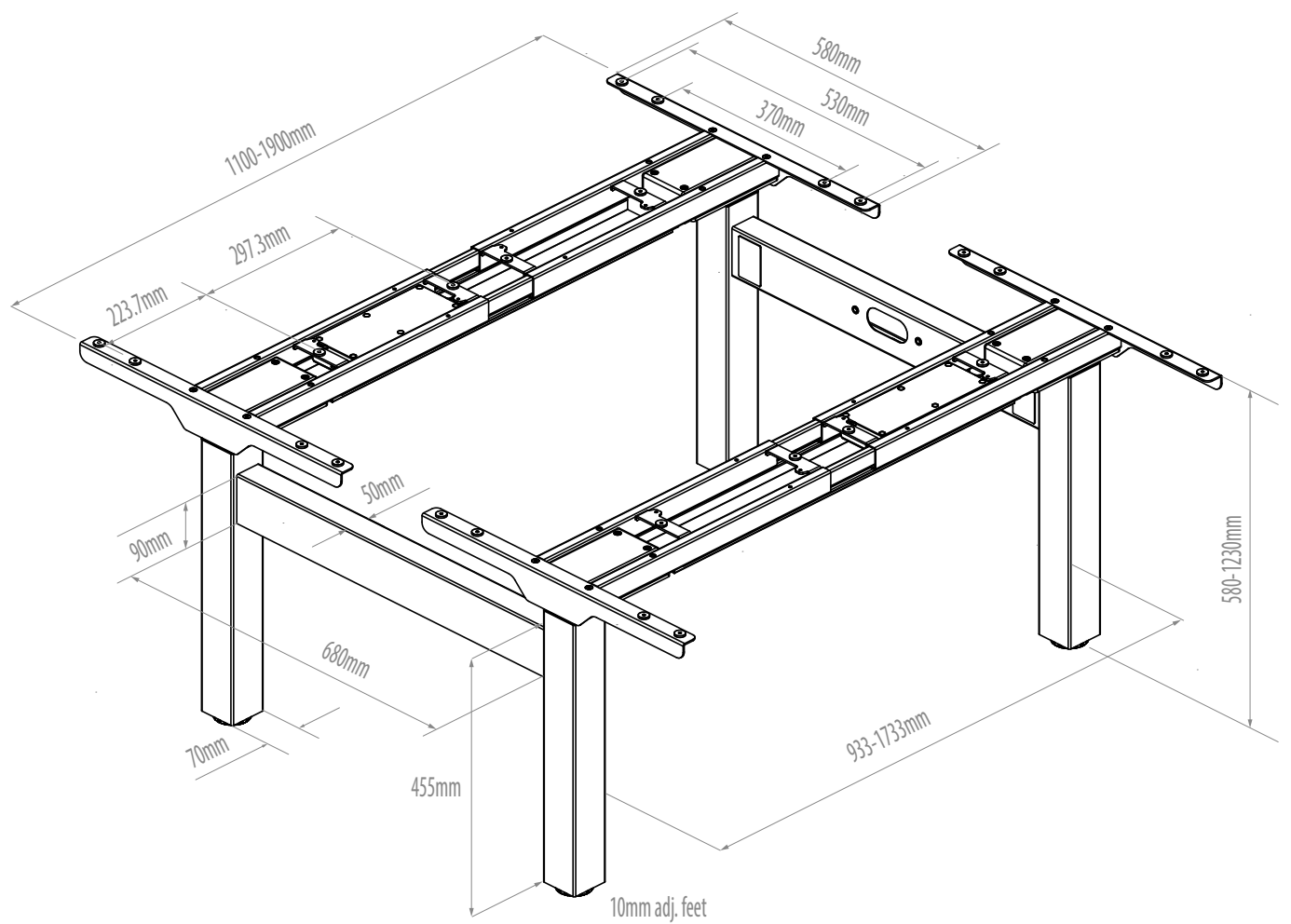

Alto 2

Desktop divider screen brackets (x2)

HAFD2-SB



Features

Easy to install

Supports almost any fabric divider screen

Colour matched to desk frame

Available in black or white

Frame Finishes	Black / White
Screen depth capacity	12-42 mm
Warranty	5 years
Boxed Dimensions	W210 x D220 x H65 mm
Boxed Weight	2kg

Alto 2

Central shared high capacity cable tray
HAFD2-CT



Features

Easy to install

Sliding lid in centre allows for easy cable management and installation of power modules

Colour matched to desk frame

Available in black or white

Frame Finishes	Black / White
Dimensions	Adjustable width x D230 x H80 mm
Warranty	5 years
Boxed Dimensions	W1020 x D260 x H110 mm
Boxed Weight	10kg

Acoustic fabric screens

Desktop divider screen / modesty panel

G4E033 / G4E015



FEATURES

- Certified sound absorption - class C
- Lightweight (lower desk load, easier to transport)
- Height-adjustable (except for Alto 2 2-desk benches)
- Visually attractive interior detail – possibility to combine 2 colours of fabric
- Option to reverse and fix screen from any side you want

QUALITY STANDARD

- LST EN ISO 354:2004
- LST EN ISO 11654:1998

TECHNICAL INFORMATION

Screen composition (42 mm)

- Frame made of 15x40 mm plywood;
- Central layer made of 10 mm polystyrene foam;
- Second layer is made of HR3030 10 mm foam from both sides;
- Third layer is made of VB2240 3 mm foam from both sides;
- Dowel pins combine two panels;
- Upholstered with 1 colour fabric or 2 colour fabric combination.



Height adjustment

(not available for Alto 2 2-desk benches)

- Screens are inserted into the fittings (154x124, H=74 mm);
- Pressed with screws to ensure stability;
- Fixed to the desktop.
- Screens can be raised / lowered to the preferred height;
- Only two screws must be tightened to ensure stability.

